

## 1.8° 42mm Hybrid Stepper Motor-NEMA17



### General Specification:

Item	Specifications
Step Angle	1.8°
Temperature Rise	80°C max
Ambient Temperature	-20°C~+50°C
Insulation Resistance	100 MΩ Min. ,500VDC
Dielectric Strength	500VAC for 1minute
Shaft Radial Play	0.02Max. (450g-load)
Shaft Axial Play	0.08Max. (450g-load)
Max. radial force	28N (20mm from the flange)
Max. axial force	10N

### Electrical Specifications:

Model No.	Step Angle	Motor Length	Current /Phase	Resistance /Phase	Inductance /Phase	Holding Torque	# of Leads	Detent Torque	Rotor Inertia	Mass
	( ° )	(L)mm	A	Ω	mH	kg.cm	No.	g.cm	g.cm	Kg
JK42HS34-0956	1.8	34	0.95	4.2	2.5	1.6	6	120	34	0.22
JK42HS34-0406	1.8	34	0.4	24	15	1.6	6	120	34	0.22
JK42HS34-0316	1.8	34	0.31	38.5	21	1.6	6	120	34	0.22
JK42HS34-1334	1.8	34	1.33	2.1	2.5	2.6	4	120	34	0.22
JK42HS34-0404	1.8	34	0.4	30	35	2.6	4	120	34	0.22
JK42HS40-0404	1.8	34	0.4	30	60	4.0	4	150	54	0.28
JK42HS40-1206	1.8	40	1.2	3.3	3.2	2.8	6	150	54	0.28
JK42HS40-0806	1.8	40	0.8	7.5	6.7	2.6	6	150	54	0.28
JK42HS40-1704	1.8	40	1.7	1.65	3.2	4.0	4	150	54	0.28
JK42HS40-0406	1.8	40	0.4	30	30	2.6	6	150	54	0.28

JK42HS40-1684	1.8	40	1.68	1.65	3.2	4.0	4	150	54	0.28
JK42HS48-1206	1.8	48	1.2	3.3	2.8	3.17	6	260	68	0.35
JK42HS48-0806	1.8	48	0.8	7.5	6.3	3.17	6	260	68	0.35
JK42HS48-0406	1.8	48	0.4	30	25	3.17	6	260	68	0.35
JK42HS48-1684	1.8	48	1.68	1.65	2.8	4.4	4	260	68	0.35
JK42HS60-1206	1.8	60	1.2	6	7	6.5	6	280	102	0.5

\*We can produce it according your requests

**Dimensions:(Unit=mm)**

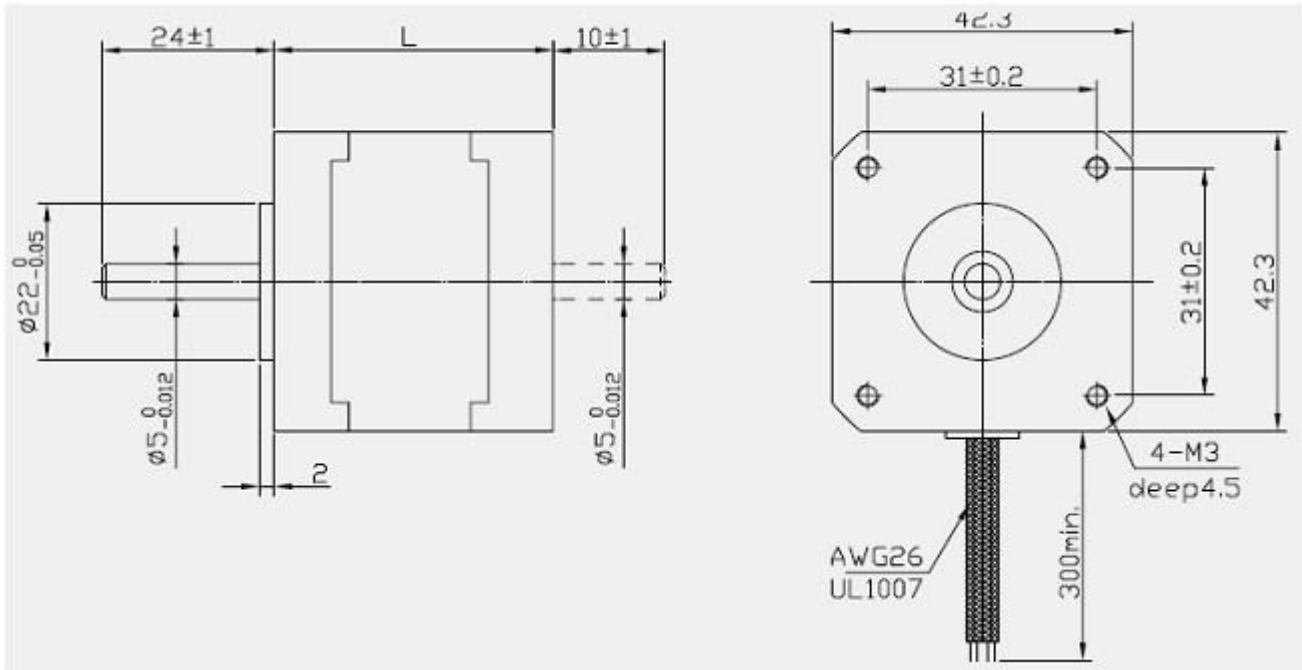

**Wiring Diagram:(接线图)**

6 LEADS

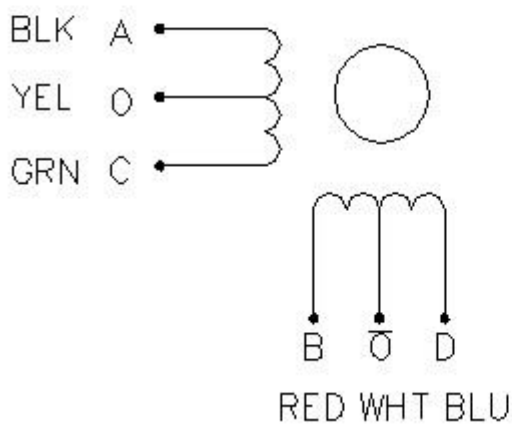

4 LEADS

